



XENOptics Advanced Robotic Fiber Management Solutions

REMOTE FIBER MANAGEMENT

The XENOptics Smart Optical Switch (XSOS- 288) breaks new ground by replacing manual Optical Distribution Frames (ODFs) and patch panels with remotely managed and fully automated systems.

The foundation of the XSOS-288 is our patented 3D optical switching (3D-OS) topology which delivers superb optical performance and complete traffic protection. Once the XSOS-288 is installed, all reconfiguration, monitoring, troubleshooting and maintenance operations can be carried out remotely.

This capability dramatically lowers the total cost of ownership of fiber infrastructure and offers very rapid return on investment.

XSOS-288: PRODUCT ARCHITECTURE

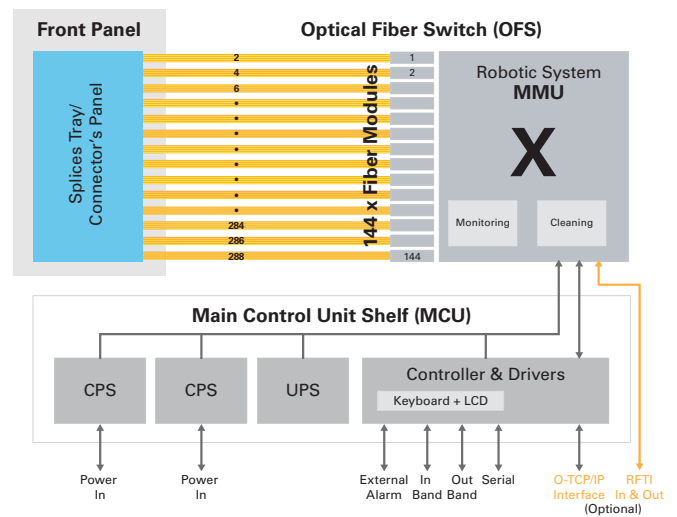

XSOS-288 FEATURES

- **Optical Switching:** A non-blocking 144x144 fiber port switching fabric.
- **Cost-Effective:** Efficient architecture enables low cost per port.
- **High single-mode Optical Performance:** Maintains uniform insertion loss of < 0.5dB and return loss < -65dB. (Optional: XSOS-576D (MM) that support multi-mode fiber switching.)
- **Carrier-Class System:** Meets applicable Telcordia and ITU recommendations. Highly reliable field-proven system units.
- **Field Replacement:** Any modules can be replaced in the field safely, without traffic interruption.
- **RFTS:** Integrated Remote Fiber Testing System.
- **Flexible Fiber Termination:** Connectivity via splices and/or connectors.
- **Synchronized Database and Auto-Discovery:** Configurations are immediately reflected in the management systems and recovered automatically in case of failure by a unique disaster recovery process.
- **Standard Software Interfaces:** WEB Graphical User Interface. SDN compliant Restful API. SNMP/TL1 equipment interfaces.
- **High Density:** Based on 3D-OS technology which provides unique fiber density and allows fiber port management of up to 1728 ports using one side of a single standard 19" rack or up to 3456 ports by using dual sides of the 19" rack (back to back).



SYSTEM ARCHITECTURE

The XSOS-288 comprises of 2 modules: **Optical Fiber Switch (OFS)** and **Main Control Unit (MCU)**.

Optical Fiber Switch (OFS)

Offers breakthrough functionality by enabling remote, non-blocking switching capabilities.

Unlike other solutions XENOptics's OFS-288 matrix features three main advantages:

- **Cost-Effective:** Price per port equivalent to manual systems.
- **Phenomenal Density:** The unique 3D-OS patented technology allows for over 3000 non-blocking fiber connections in a single rack.
- **High Reliability:** All the components used by XENOptics are of the highest level of quality. XENOptics has signed technology partnerships with major high-end global vendors to supply, assemble, test and support key components.

The 3D-OS robotic system combines active switching with a passive latching mechanism, enabling automated provisioning and configuration while ensuring traffic flow during field replacement operations. In addition, during a power loss, state configuration changes in-progress will be completed safely with the aid of an inbuilt super-capacitor UPS and all provisioned services will remain active due to our passive latching mechanism.

The OFS comprises of the following 2 main modules: a single MMU (Main Manipulator Unit) and 144 Fiber Modules (FM). It is accompanied by a remote diagnostics camera, environmental sensors and a dust cleaning extraction unit to maintain high optical performance.

Main Control Unit (MCU)

This controls all switching elements. It monitors real-time status of cross-connections and network performance. It also transmits data and alarms to the central network management system. It provides in-band and out-band functionality with Telnet, SSH, Restful API and SNMP/TL1 interfaces.

The MCU comprises of the following modules:

- Dual redundant power supplies (-48 DC or 110-220AC)
 - UPS that support the system in case of power failure.
- Real time controller, strong processing unit and drivers to support the MMU.

XSOS-FAMILY INTERFACES

Parameter	Unit
Serial	RS-232 interface for local or maintenance operation.
SD card	An interface to support SD cards that may use for SW versions update, install and store data base and to support network configurations.
In Band	Standard SNMP interfaces into XENOptics's Element/Network Manager for the whole network. HTTP, HTTPS, SNMPv2/v3, Telnet, SSH, TFTP, NTP and Restful API.
Out of Band	Standard SNMP interfaces to be connected and managed by higher SW layers.
GPS	GPS antenna interface (for OSP applications).
Dual Power In	<ul style="list-style-type: none"> • 110 / 220 Volt AC interface • (Optional) Dual feed power 48V input for main CO power source and backup CO source
External Alarm	10 ports: 4 x dry contact inputs, 4 dry contact outputs (normally closed), 2 programable input/output ports.
Keypad + LCD	A 5 command keys + display to control the system locally.
System Status Indication	Green, yellow, red LEDs to indicate the status of the system: Normal, warning, Alarm.
Optical Port Status	On the top of each optical port on the panel, there is a LED that supports 3 colors to present the port status: connected, not connected, temporary not in use.
Power On	A red LED is amounted on the power supply front, indicates the power supply unit status.

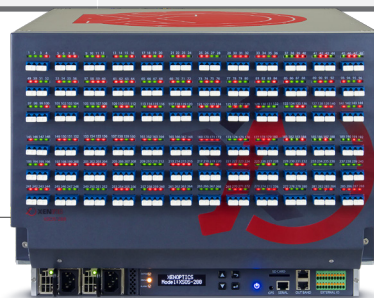

MANAGEMENT

Web Graphical User Interface: Provides a simple and intuitive interface for remotely connecting/disconnecting fibers and controlling the XSOS platform from a standard desktop browser and mobile IOS/Android devices.

Local Terminal Management: Provides a simple interface to a dumb terminal with a command line interface that is primarily used in installation and maintenance modes by technicians during unit servicing.

Element Management System (EMS): Offers an overall system view, topology connectivity and provisioning of the overall fiber infrastructure, system by system, interfaced through the equipment using Restful API and SNMP/TL1 interface.

Network Management System: Provides full network view and supports end-to-end operations using Restful API and SNMP/TL1 interfaces.

APPLICATIONS

- Data Centers
- Colocation DC providers
- Meet-me-rooms
- Cloud computing, Server farms
- Hyperscalers
- Laboratories and Testing systems
- Internet exchanges
- Central offices and edge locations
- FTTx Networks
- MDU distribution
- Utility Networks

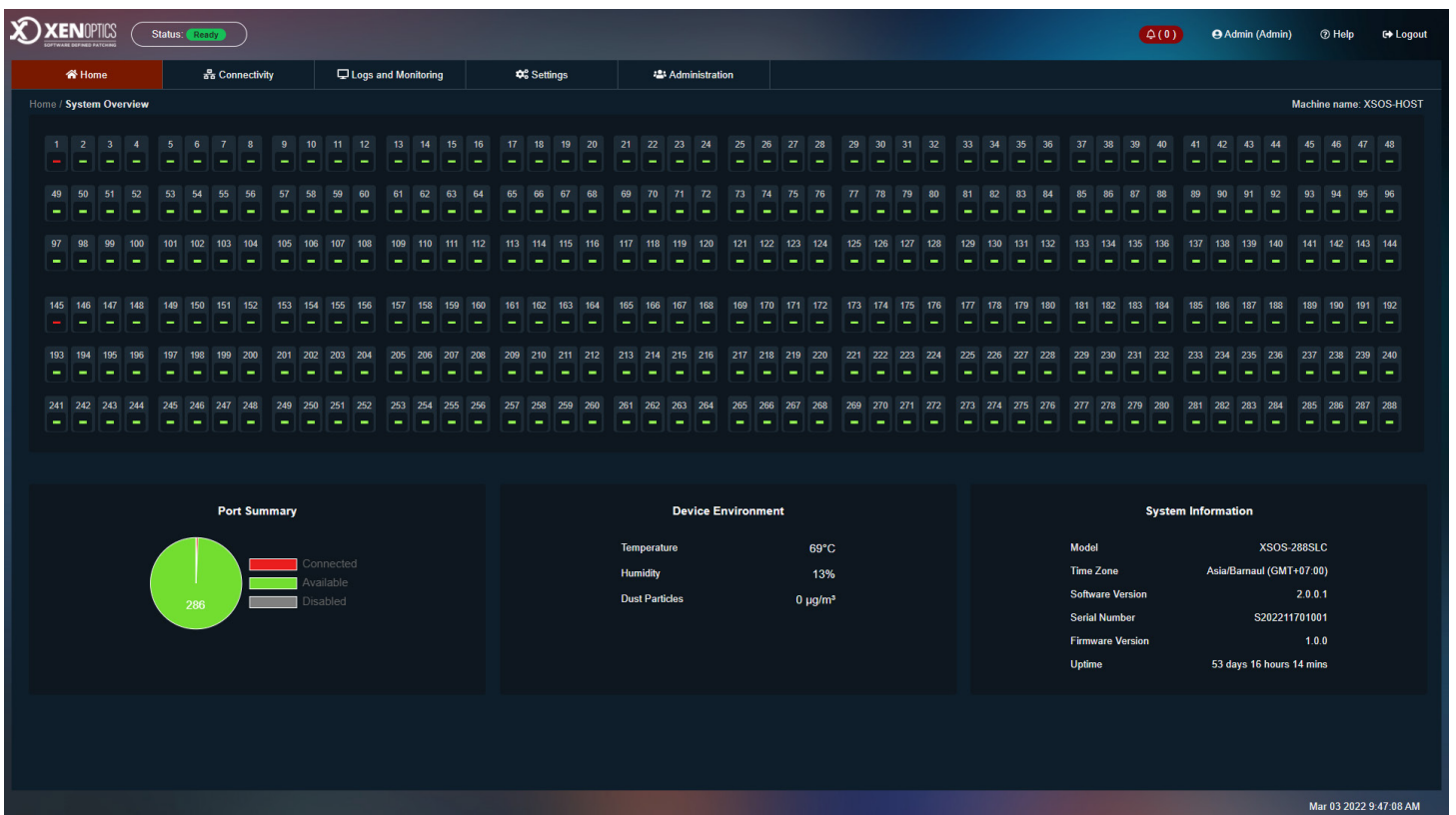

▲ Web Graphical User Interface

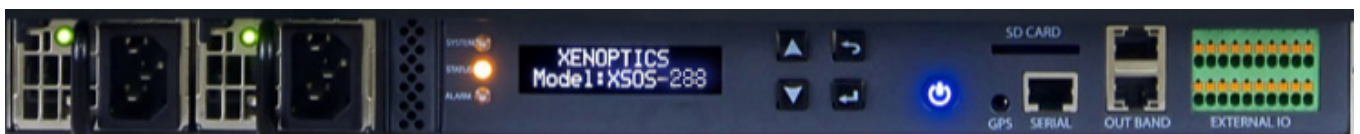

▲ Main Control Unit

SPECIFICATIONS: SINGLE MODE FIBER

Parameter	Unit	Min	Typical	Max
OPTICAL CHARACTERISTICS				
Operating Range	nm	1260		1630
Insertion Loss (spliced version)	dB		0.25	0.5
Insertion Loss (connectorized version)	dB		0.50	0.8
Insertion Loss Repeatability	dB		0.06	0.1
Crosstalk	dB			-70
Return Loss (UPC/APC)	dB			-55 / -65
PDL	dB			0.15
PMD	psec			0.1
Input Power	dBm			25
Switching Time	Sec		35	60
POWER REQUIREMENTS				
Input Voltage	V _{DC}		110-220	
Input Voltage (optional)	V _{DC}	-40		-75
Power Consumption (switching Operation)	W			50
Power Consumption (standby)	W			6
Power Consumption (sleep mode for OSP)	W	0.1		0.5
ENVIRONMENTAL CONDITIONS				
Temperature Range	°C	-5		+45
Temperature Range (street cabinet)	°C	-40		+65
Temperature Range (Transport)	°C	-40		+70
Relative Humidity	%	10		95

DIMENSIONS

XSOS - 288	Height	Width	Depth
Splices configuration	334 mm	441 mm	450 mm
Connectors configuration	334 mm	441 mm	497 mm
Weight	29.7 Kg		

APPLICABLE STANDARDS

Environmental	ETSI 300019 CLASS 3.2
EMC	EN 55022 CLASS B, IEC 1000-4-2-6
Safety	EN 60950, IEC 825-1; IEC 825-2, GR-1089-CORE
ESD	IEC-61000-4-2
EU Environmental	ETS-300 019
US Environmental	NEBS 3, GR-63-CORE



Connect with us
www.xenoptics.com
info@xenoptics.com

Australia (HQ)
 10 Westall Road
 Springvale
 VIC 3171

Thailand
 195 M3 Bypass
 Chiangmai-Handong
 T. Namphae, A. Handong
 Chiang Mai, 50230

Israel
 4 Barash Street
 Kiryat Ono
 55558

Europe
 Eichendorffstr. 55
 60320 Frankfurt
 Germany